

MILK COOLING TANK WITH DIRECT EXPANSION REM/DX 1050 - 15000 L

Fullwood Packo

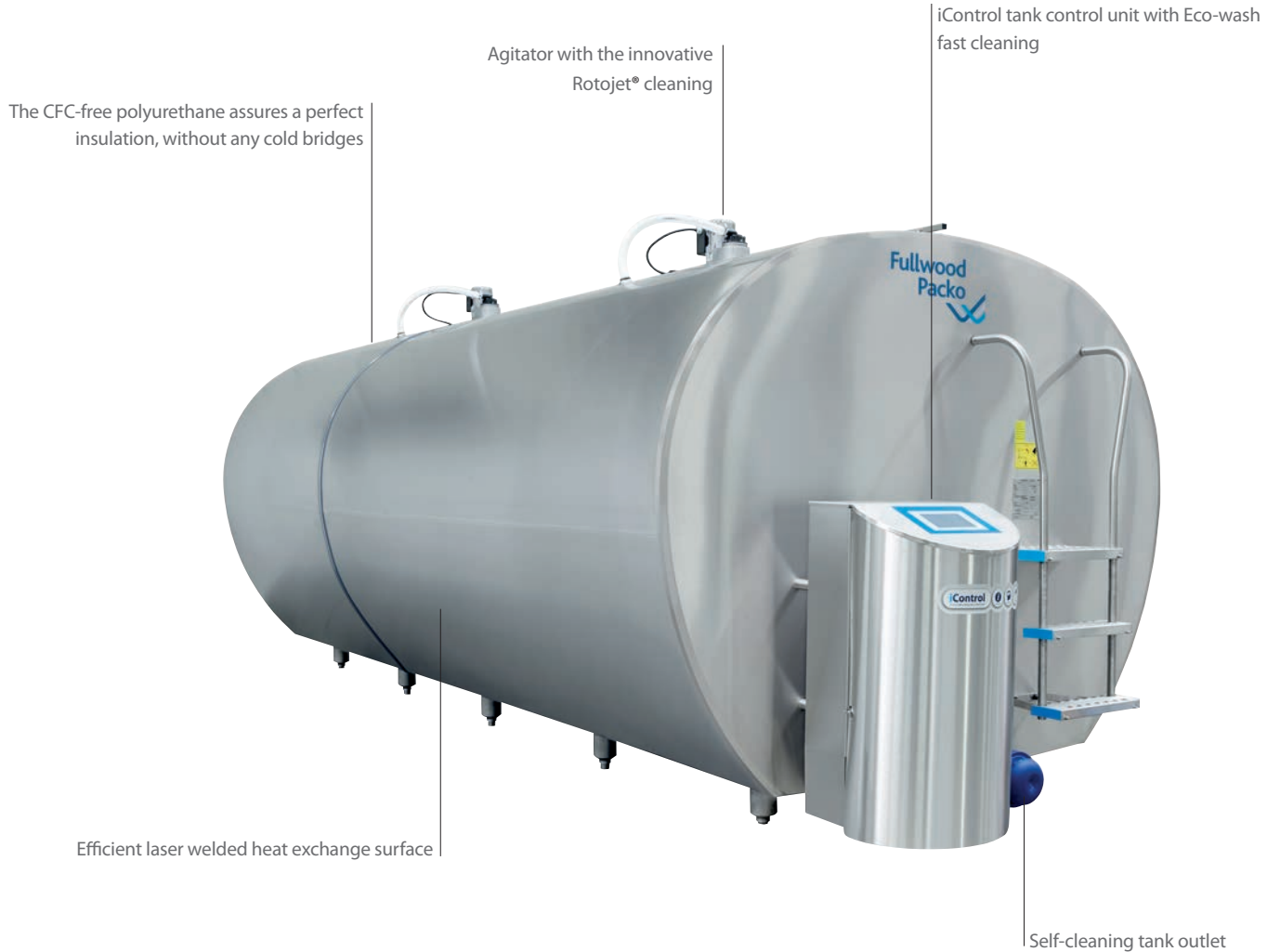

Construction

- Construction completely made in stainless steel 18/10 – AISI 304
- Insulated with polyurethane for an excellent insulation and extra strength of the tank
- Horizontal tank with an efficient laser welded multi-injection evaporator; thanks to the free circulation and a good agitation of the milk there is an optimal heat exchange
- For tanks REM/DX 2100 litres and smaller: tank outlet Ø 50 mm, self-cleaning outlet with butterfly valve Ø 50 mm and truck connection Ø 50 mm
- For REMDX tanks bigger than 2100 litres: tank outlet Ø 80 mm, self-cleaning outlet with butterfly valve Ø 80 mm and a truck connection Ø 80 / 65 or 50 mm
- All models bigger than 2100 litres have a stainless steel ladder

Cooling and cleaning

- Thanks to the innovative iControl tank control unit the milk quality is assured
- Full automatic logging of the cooling, agitation, cleaning and potential alarms
- Eco-wash fast cleaning integrated for less water use and saving time during cleaning (up to 50% savings)
- Two automatic dosing pumps for detergents
- Detection 'nearly empty' for two detergent containers
- Dynamic Fullwood Packo-ROTOJET[®] cleaning system with spray balls built in the agitator paddle
- Vertical mounted stainless steel cleaning pump, no risk of freezing

Important options

- Oculus tank guard
- Tank executed for robotic milking
- Bottom filling
- Eco-drain (second drain valve)
- Messages via SMS
- PACAP digital volume measurement
- Additional energy savings during cooling in combination with the Fullwood Packo Eco-Tronic electronic injection valve

DIMENSIONS

REM/^{nv}

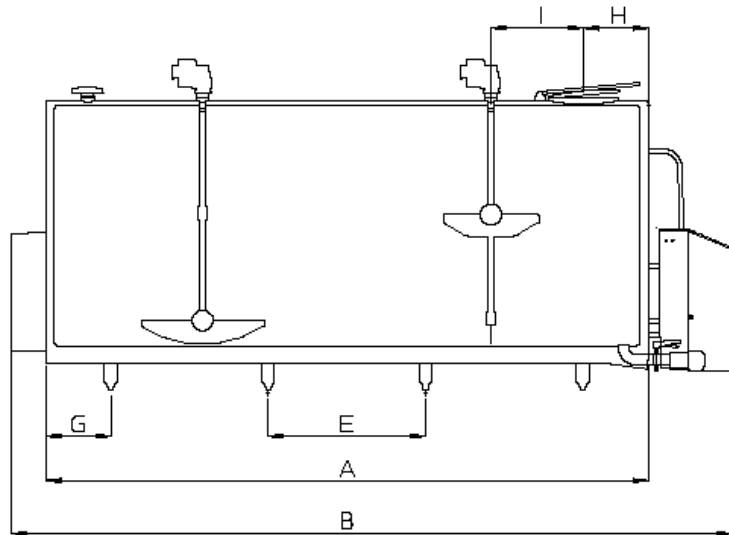
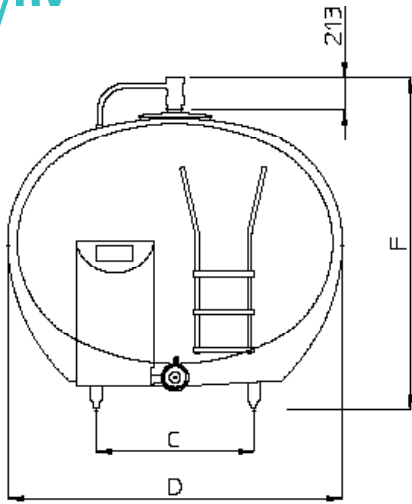

Model	Max. vol.	A	B	C	D	E	F	G	H	I	# Legs	Weight
REMDX	litres	mm	mm	mm	mm	mm	mm	mm	mm	mm		kg
1050	1125	1398	2204	670	1308	932	1511 - 1556	233	432	430	4	220
1300	1393	1704	2510	670	1308	845	1517 - 1562	430	432	470	4	295
1700	1715	2070	2876	670	1308	1210	1524 - 1569	430	432	603	4	365
2100	2140	2553	3359	670	1308	1690	1534 - 1579	432	432	845	4	412
2600	2653	1911	2694	750	1660	1210	1871 - 1916	351	432	524	4	437
3100	3186	2722	3505	750	1660	1440	1887 - 1932	416	432	704	4	500
3800	3944	2504	3289	934	1800	1690	1869 - 1914	407	432	820	4	590
4400	4562	2874	3659	934	1800	1050	1876 - 1921	387	432	1005	6	667
5000	5128	3214	3999	934	1800	1210	1883 - 1928	397	432	1175	6	730
RS 5000	5159	2380	3165	1050	2100	1580	2086 - 2130	400	432	758	4	710
6150	6321	2894	3679	1050	2100	1050	2096 - 2141	397	432	1015	6	854
7200	7369	3354	4139	1050	2100	1210	2105 - 2150	467	432	1245	6	901
RS 8000	8199	3140	3925	1050	2233	870	2248 - 2293	265	432	1138	8	1065
8200	8406	3809	4594	1050	2100	1050	2114 - 2159	330	432	556	8	1090
9000	9566	3681	4466	1050	2233	1050	2259 - 2303	266	432	531	8	1155
10000	10482	4011	4796	1050	2233	1050	2265 - 2310	431	432	611	8	1229
12000	12602	4810	5595	1050	2233	1050	2281 - 2326	305	432	813	10	1450
15000	15782	5986	6771	1050	2233	1050	2305 - 2349	368	432	1113	12	1800

All the above values are for tanks with the iControl Eco-wash control unit and a standard self-cleaning outlet (NW50, NW65 or NW80)
Other outlet options on request

- With PCV3 control unit: B - 190 mm
- With bottom filling - 1 supply line: B + 60 mm
- F = min. and max. height leg screw when installing the tank under 2% slope
- With the tank guard Oculus: F + 25 mm
- With volume measurement Pacap: F + 15 mm

REM/DX

available in 2, 4 & 6 milkings and robotic milking

RS/DX

available in 4 & 6 milkings and robotic milking

REM/DX 1050-5000 - RS/DX 5000

1 agitator with 1 built-in ROTOJET-spray ball

REM/DX 6150-7200 - RS/DX 8000

1 agitator with 2 built-in ROTOJET-spray balls

REM/DX 8200-15000

2 agitators with 4 built-in ROTOJET-spray balls

Fullwood Packo nv

Torhoutsesteenweg 154 - 8210 Zedelgem - Belgium

T +32 50 25 06 10 - E cooling@fullwoodpacko.com

www.packocooling.com

Subject to modifications. Not contractually binding document.